

# The effect of magnetic field on the anisotropy of the ultrasonic attenuation in magnetic liquids

A Skumiel, M Łabowski and T Hornowski

Institute of Acoustics, A Mickiewicz University, ul Jana Matejki 48/49, 60-769 Poznań, Poland

Received 18 June 1996, in final form 2 September 1996

**Abstract.** Experimental results for the DC magnetic field influence on the anisotropy of attenuation of ultrasound in ferrofluids are presented. The measurements were performed for the frequency 1.18 MHz, at the temperatures 10 and 40 °C, with magnetic field strengths  $H = 39.8, 79.58$  and  $159.15 \text{ kA m}^{-1}$ . Comparison of the experimental results with the Taketomi theory allowed the determination of the cluster radius and the number density of the colloidal particles.

## 1. Introduction

A magnetic liquid, when acted on by an externally applied DC magnetic field, exhibits highly specific changes in its physical properties. Whereas in the absence of a magnetic field the magnetization vectors of the magnetic particles are directed randomly due to thermal motion so that the macroscopic sample as a whole shows no magnetization, an external magnetic field will align the particles along the lines of the field. Moreover, since the particles are in fact small magnets, they coalesce in such a manner as to form long chain-like structures.

However, magneto-optical experiments [1, 3] show that there arise spherical clusters composed of magnetic particles of a size dependent on many factors (such as the temperature, the strength of the magnetic field and the concentration of the particles). In an external magnetic field, the clusters form chains directed along the lines of the field, thus enhancing the stiffness of the liquid. This in turn affects the acoustic properties of the latter. The size of the clusters and the length of the chains they form are primarily dependent on the magnetic field strength and the temperature. The energy of an ultrasonic wave propagating in a thus-structured liquid is spent on exciting the translational and rotational degrees of freedom of the clusters.

Our present work was intended to determine which of the above mechanisms predominates depending on the external experimental conditions. We thus gleaned an amount of valuable information on the structure of magnetic liquids, in particular concerning the radius of the clusters and their concentration.

## 2. Theoretical details

The anisotropy of the ultrasonic attenuation, namely the dependence of the coefficient of absorption on the angle between the direction of the magnetic field and the propagation of the acoustic wave, has been studied repeatedly [1, 3]. Its discovery in the late 1970s is due to Chung and Isler [1]. Earlier, Parsons [2] had proposed a formula for the ultrasonic attenuation predicting it to vary in accordance with the function  $\sin^2(2\phi)$ . However, experiment failed to confirm this.

After Taketomi [3], the amplitude ultrasonic attenuation  $q$  of an ultrasonic wave propagating in a magnetic liquid acted on by an external magnetic field consists of two parts, related respectively to rotational motion of the clusters  $q_r$  and their translational motion  $q_t$ . In his theory, Taketomi introduced a magnetization vector, referred to the cluster. He, moreover, assumed that the clusters in the external magnetic field tend to form long chains along the lines of the field. The clusters—activated by the acoustic field—perform translational and rotational motions simultaneously. This is an irreversible process dissipating the energy of the acoustic wave into heat.

The two mechanisms affecting the absorption coefficient are given as [1]

$$q_r = \frac{\omega^2}{2\rho_0 c^3} [\alpha_4 + \mu_1 + 2\alpha_5(\cos \phi)^2 + \alpha_1(\cos \phi)^4] \quad (1)$$

$$q_t = \frac{1}{ck^2} \frac{3\pi\eta_0 a \omega^3 V N (6\pi\eta_0 a + \rho_0 V \omega)}{(\sin \phi - \rho_m V \omega^2/k)^2 + (6\pi\eta_0 a \omega/k)^2} \quad (2)$$

where  $\alpha_4 = 2\eta_0$ ,  $\mu_1 = \eta_v - 2\eta_0/3$ ,  $\rho_m = 5180 \text{ kg m}^{-3}$  is the density of the magnetic particle in suspension,  $\rho_0$  is the

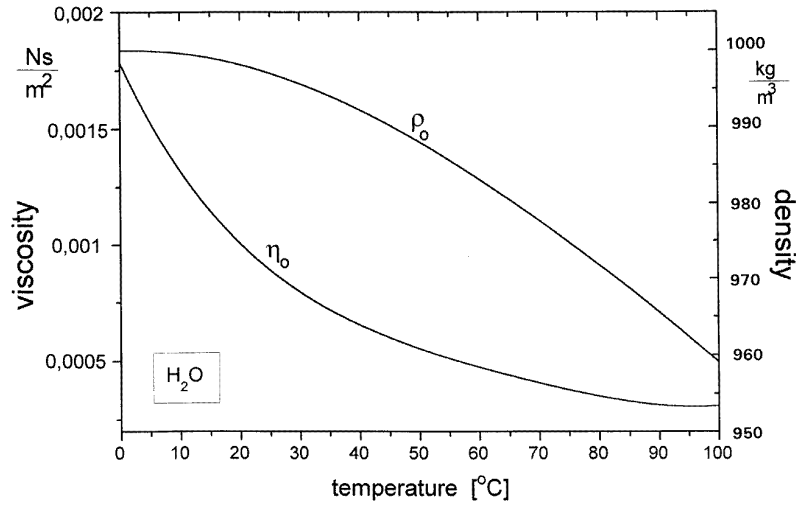

**Figure 1.** Shear viscosity  $\eta_0$  and density  $\rho_0$  versus temperature in pure water.

**Table 1.** Values determined for the magnetic liquid for an ultrasonic wave of frequency 1.18 MHz.

$T$ (°C)	$c$ (m s <sup>-1</sup> )	$\rho_0$ (kg m <sup>-3</sup> )	$10^3 \eta_0$ (N s m <sup>-2</sup> )	$b_0$ (s kg <sup>-1</sup> )	$10^{-13} b_1$ (N <sup>2</sup> m <sup>-5</sup> )	$10^{-12} b_2$ (m <sup>-2</sup> )	$10^{-17} b_3$ (kg s <sup>-2</sup> m <sup>-3</sup> )	$10^{-8} b_4$ (kg <sup>2</sup> s <sup>-4</sup> m <sup>-2</sup> )
10	1418.02	999.7	1.3077	9.642	36.575	1.26	11.93	334.0
40	1449.23	992.2	0.656	9.101	9.006	2.492	11.93	84.05

density of the solvent,  $V = 4\pi a^3/3$  is the volume of the cluster,  $a$  is its radius,  $N$  is the number of clusters per unit volume,  $\eta_0$  is the shear viscosity of the solvent,  $\alpha_1, \alpha_4, \alpha_5$  and  $\mu_1$  are Leslie's coefficients occurring in the theory of liquid crystals,  $k$  is the elasticity constant of the liquid and  $c$  is the propagation velocity of the ultrasonic wave in the magnetic liquid. The first term of equation (1), free from anisotropy, is the coefficient of attenuation of the wave due to shear and volume viscosity, since  $\alpha_4 + \mu_1 = 4\eta_0/3 + \eta_v$ .

In order to determine the values of  $\alpha_4 + \mu_1, \alpha_5, \alpha_1, N, k$  and  $a$  occurring in equations (1) and (2), we introduce the following notations:  $A_0 = \alpha_4 + \mu_1 = -\alpha_5, A_1 = \alpha_1, A_2 = N, A_3 = k$  and  $A_4 = a$ . The two equations now take the form

$$q_r = \frac{2\pi^2 f^2}{\rho_0 c^3} [A_0(1 - 2\cos^2 \phi) + A_1 \cos^4 \phi] \quad (3)$$

$$q_t = \frac{192\pi^6 f^3 \eta_0^2 c^{-1} A_2 A_4^5 \left(1 + \frac{4\pi f \rho_0}{9\eta_0} A_4^2\right)}{\left(A_3 \sin \phi - \frac{16\pi^3 f^2 \rho_m}{3} A_4^3\right)^2 + 144\pi^4 f^2 \eta_0^2 A_4^2} \quad (4)$$

When fitting the function  $q_r + q_t$  to the experimentally determined values of the absorption coefficient we have to take into account the temperature-dependences of  $\eta_0, \rho_0$  and  $c$  for each value of the temperature. Otherwise, despite the formally good fitting of  $q_r + q_t$  to the experimental points, the values of  $\alpha_4 + \mu_1, \alpha_5, \alpha_1, N, k$  and  $a$  thus obtained would be charged with considerable error. Figure 1 shows  $\eta_0$  and  $\rho_0$  versus temperature [4].

With the notation

$$b_0 = \frac{2\pi^2 f^2}{\rho_0 c^3} \quad b_1 = \frac{192\pi^6 f^3 \eta_0^2}{c} \quad b_2 = \frac{4\pi f \rho_0}{9\eta_0}$$

$$b_3 = \frac{16\pi^3 f^2 \rho_m}{3} \quad b_4 = 144\pi^4 f^2 \eta_0^2 \quad (5)$$

we finally get

$$q = b_0(A_0 - 2A_0 \cos^2 \phi + A_1 \cos^4 \phi) + \frac{b_1 A_2 A_4^5 (1 + b_2 A_4^2)}{(A_3 \sin \phi - b_3 A_4^3)^2 + b_4 A_4^2} \quad (6)$$

The formula (6) considerably simplifies the procedure of fitting the Taketomi function to the experimental results. In table 1 we list the values of the various quantities and coefficients determined by us for the magnetic liquid under investigation, for an ultrasonic wave of frequency  $f = 1.18$  MHz, assuming the density of the magnetic particles to be  $\rho_m = 5180$  kg m<sup>-3</sup>.

The propagation velocity of the wave at different temperatures of the magnetic liquid was determined by the echo-overlap method [5]. By fitting the Willards function to the experimental points we obtained for the temperature-dependence of the velocity  $c$  (m s<sup>-1</sup>) = 1450.05 - 0.0251(45.725 - T)<sup>2</sup>.

### 3. The measurement set-up

The measurement set-up for the determination of the anisotropy of the ultrasonic attenuation (figure 2) consisted of panels made by Matec. The set-up acted on the pulse method and was supplemented with a block of the type Model 2470B. It comprised circuits delaying the pulses of the consecutive echoes and two channels with analogue memories recording the values of the respective

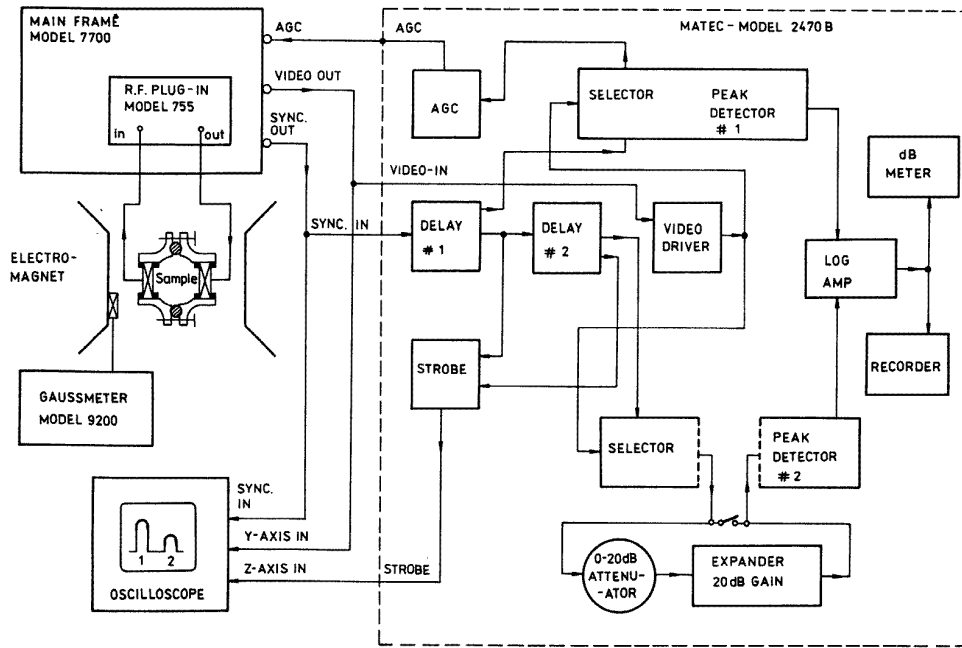

**Figure 2.** The block diagram of the experimental set-up for measuring the absorption coefficient of the ultrasonic wave propagating in a magnetic liquid under the influence of a DC magnetic field.

**Table 2.** Values obtained for fitting the function describing the anisotropy of the ultrasonic absorption coefficient to the measured points.

$H$ (kA m <sup>-1</sup> )	$T$ (°C)	$\alpha_4 + \mu_1$ (N s m <sup>-2</sup> )	$\alpha_1$ (N s m <sup>-2</sup> )	$N$ (10 <sup>16</sup> m <sup>-3</sup> )	$k$ (N m <sup>-1</sup> )	$10^6 a$ (m)
39.8	10	3.702	7.78	1.2	0.3058	0.55
79.58	10	1.67	5.55	1.3	0.2241	0.51
159.15	10	0.51	4.45	1.4	0.1878	0.52
39.8	40	0.8	3.54	2.3	0.1649	0.51
79.58	40	3.01	4.62	25.0	0.0273	0.2
159.15	40	2.06	5.17	4.0	0.0561	0.32

echoes. Hence the two constant-voltage electric signals, proportional to the amplitudes of the echoes memorized, were fed into the logarithmic amplifier the output voltage of which was consequently proportional to the amplitude coefficient of absorption of the wave in the medium. The accuracy provided by our set-up amounted to  $\pm 2$  m<sup>-1</sup>.

The magnetic field induction in the slit between the poles of the electromagnet was measured to within 0.5% with a Bell 9200 gaussmeter. The temperature in the sample was stabilized within  $\pm 0.01$  K.

Our studies of the ultrasonic attenuation coefficient were performed on a water-based magnetic liquid, denoted by the symbol EMG-605. The magnetic liquid was characterized by the following physical properties [6]:

- (i) magnetic saturation 20 [mT],
- (ii) initial magnetic susceptibility  $\chi_0 = 0.5$ ,
- (iii) volume concentration of magnetic particles (physical concentration)  $\Phi_M = 3.5\%$ ,
- (iv) shear viscosity coefficient  $\eta < 0.05$  P at 27 °C and
- (v) the size of the magnetic particles obeyed a normal distribution, with a maximum probability density for a radius of 100 Å.

The liquid was contained in a brass vessel at a constant distance of  $l = 0.01684$  m between two quartz transducers, with a basic frequency of  $f = 1.18$  MHz at an easily controlled distance from each other. The measurements were performed at 10 and 40 °C in magnetic fields of  $H = 39.8, 79.58$  and  $159.15$  kA m<sup>-1</sup> varying the angle  $\phi$  between the vectors  $\mathbf{H}$  and  $\mathbf{k}$  in the range from 0–0.5 $\pi$  radians.

#### 4. Results

Figures 3(a) and (b) exemplify values of the ultrasonic absorption coefficient determined at 10 and 40 °C respectively in an external field of  $H = 79.58$  kA m<sup>-1</sup> at  $\phi$  varying from 0 to 0.5 $\pi$  rad and show the curves given by formula (6) together with their rotational part  $q_r$  and translational part  $q_t$ . With increasing temperature the maximum of  $q_t$  as well as the minimum of  $q_r$  shift towards smaller angles  $\phi$ .

From the results shown in figures 3(a) and (b), the anisotropy of the absorption coefficient of ultrasonic waves propagating in the magnetic liquid acted on by a DC

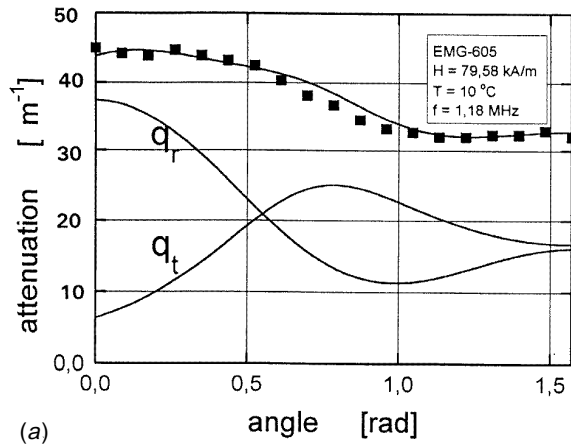

(a)

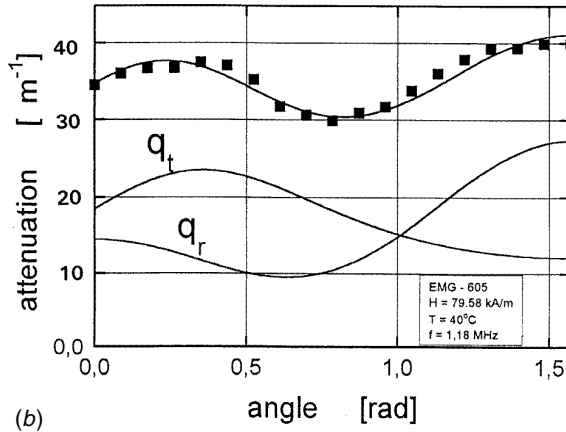

(b)

**Figure 3.** Ultrasonic attenuation anisotropy in a magnetic liquid under the influence of a DC magnetic field: (a)  $T = 10\text{ }^\circ\text{C}$  and (b)  $T = 40\text{ }^\circ\text{C}$ .

magnetic field of  $H = 79.58\text{ kA m}^{-1}$  is expressible, respectively, by the following numerical formulae:

$$q\text{ (m}^{-1}\text{)} = 16.1 - 32.2 \cos^2 \phi + 53.5 \cos^4 \phi + \frac{217800}{(224.1 \sin \phi - 158.3)^2 + 8687}$$

for  $10\text{ }^\circ\text{C}$  and

$$q\text{ (m}^{-1}\text{)} = 27.4 - 54.8 \cos^2 \phi + 42 \cos^4 \phi + \frac{7923}{(27.3 \sin \phi - 9.544)^2 + 336.2}$$

for  $40\text{ }^\circ\text{C}$ .

In table 2 we give the values of  $\alpha_4 + \mu_1$ ,  $\alpha_1$ ,  $N$ ,  $k$  and  $a$  obtained by fitting the function describing the anisotropy of the ultrasonic absorption coefficient to the measured points under different thermodynamical conditions. Table 2 shows that, with increasing temperature of the magnetic liquid, the radius of the clusters decreases and simultaneously their number density in the liquid increases. It is worth stressing that, under the thermodynamical conditions applied, the quantity  $4\pi a^3 N/3$ , determining the total volume of the clusters present per unit volume of the magnetic liquid, takes but slightly differing values. This shows that most of the magnetic particles in the magnetic liquid belong to clusters.

## 5. Summary

Our results show that the ultrasonic absorption coefficient of a wave propagating in a magnetic liquid in a DC magnetic field depends on the translational and rotational degrees of freedom. The part played by other factors is obviously dependent on the angle between the external magnetic field and the propagation vector, as well as on the thermodynamical conditions. Moreover, our measurements provide information concerning, for example, the radius of the clusters, their concentration and other quantities characterizing the magnetic liquid.

Our theoretical curves are in very good agreement with our experimental results, corroborating the theory of Taketomi. However, quite recently, a new theory well adapted to experimental verification was proposed [7] for ultrasonic wave propagation in magnetic liquids acted on by a DC magnetic field.

## Acknowledgment

This work was supported by grant 2PO3B 17908 from the Polish Committee for Scientific Research.

## References

- [1] Isler W E and Chung D Y 1978 *J. Appl. Phys.* **49** 1812–4
- [2] Parsons J D 1975 *J. Phys. D: Appl. Phys.* **8** 1219–26
- [3] Taketomi S 1986 *J. Phys. Soc. Japan* **55** 838–44
- [4] 1974 *Physical-Chemical Handbook* (Warsaw: WNT)
- [5] Skumiel A Łabowski M and Hornowski T 1995 *Akustyka Molek. Kwant.* **16** 225–32 (in Polish)
- [6] Ferrofluidics Corp., Burlington Massachusetts
- [7] Henjes K 1994 *Phys. Rev. E* **50** 1184–8